

Western Dragon

Designed in 2007 by Cheng Heng Yi, Singapore

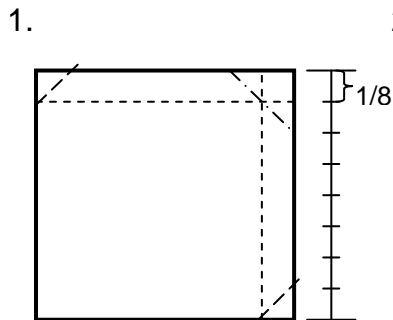

Fold along the above creases to form an offset preliminary base.

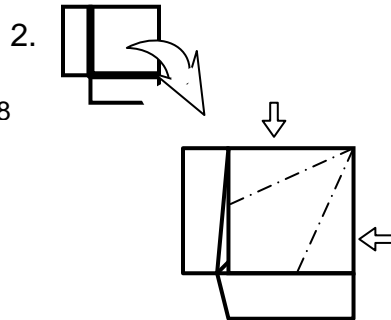

Enlarged view of preliminary base. Reverse fold the sides in so they meet in the centre.

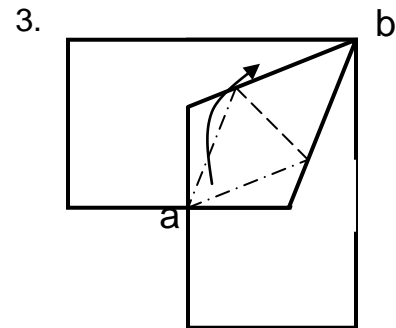

Petal – fold to let point a touch point b.

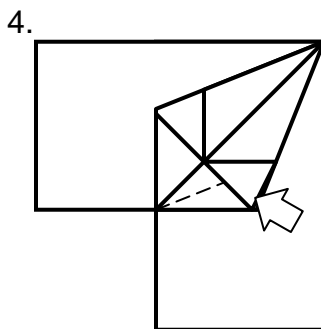

Swivel - fold the flap to under the center flaps. Repeat on the other side.

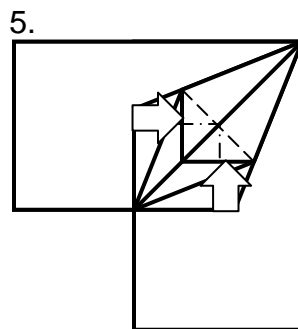

Squash fold the center flaps to form the eyes.

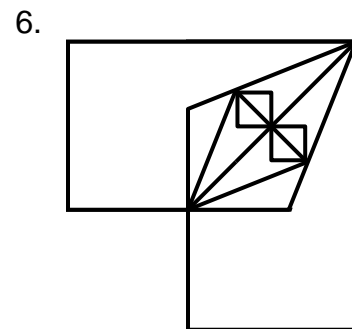

Reverse the flaps on the eye to change its color.

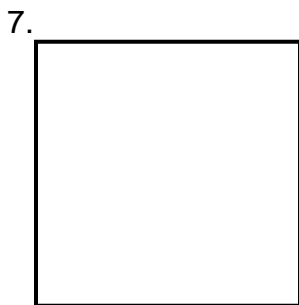

From now on up to step 20, we will disregard the head of the dragon and treat this as an original square.

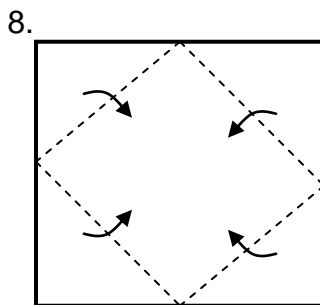

Valley fold the four corners in to form a blintz base.

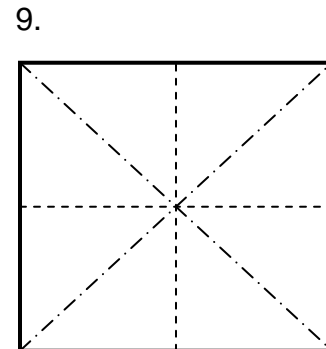

Form a waterbomb base with the blintz base. Make sure the free flaps of the blintz base are outside the preliminary base.



10.

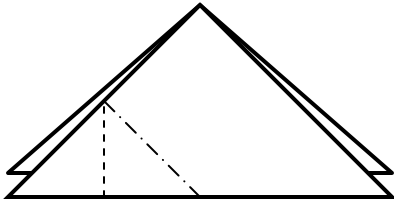

Crimp as shown. Repeat on the right side and behind.

12.

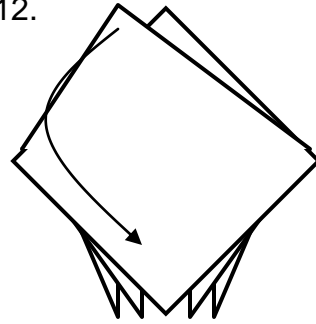

Pull out the extra layer formed in the blintz base as far as it can go. Let the model unfold a little.

13.

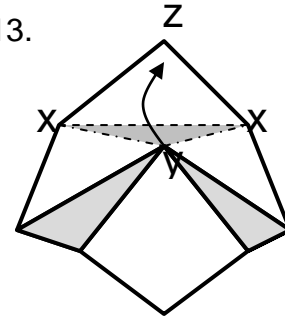

Pull the corner labeled y up to touch corner z. Note the location of the x points.

14.

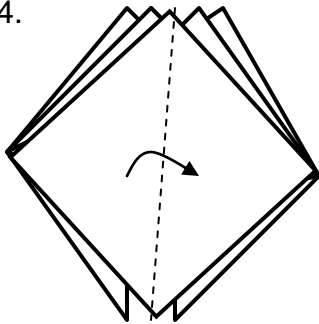

Valley fold one flap to the left.

15.

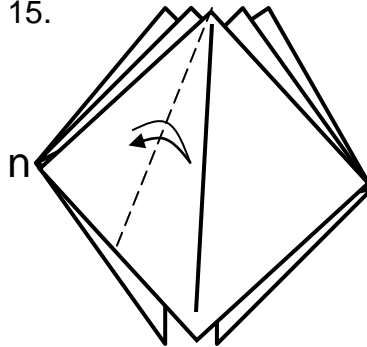

Precrease as shown. Fold through all the layers. Open the model and turn it so point n is facing you.

16.

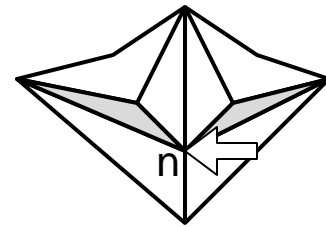

Push point n in on the crease you made in step 15. Collapse the model flat.

17.

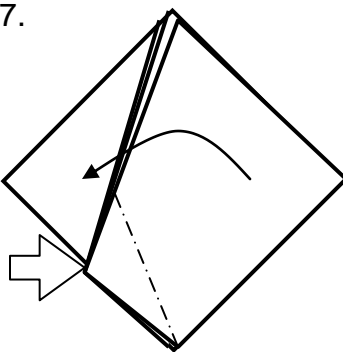

Spread – squash the corner flat. Repeat steps 14 – 17 on the right side and behind.

18.

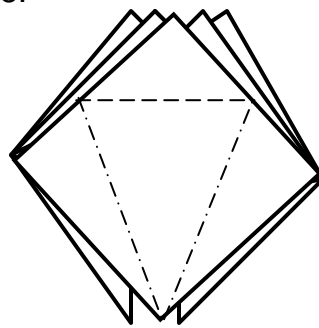

Make sure that the head of the dragon is in front. Petal – fold the flap like a bird base. Repeat behind.

19.

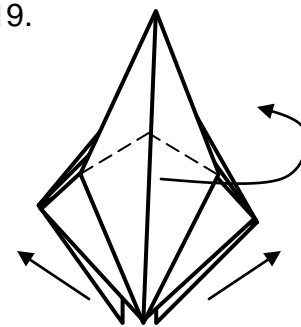

Pull out the 2 flaps of the remaining “preliminary bases”. Rabbit fold as shown. Repeat behind.

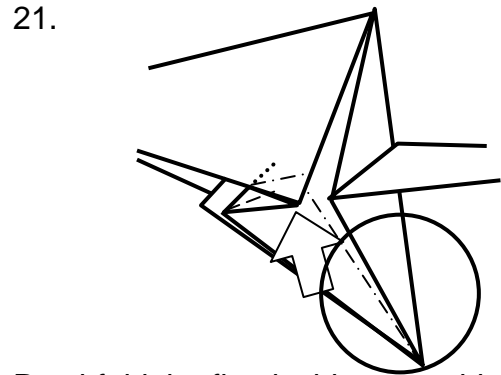
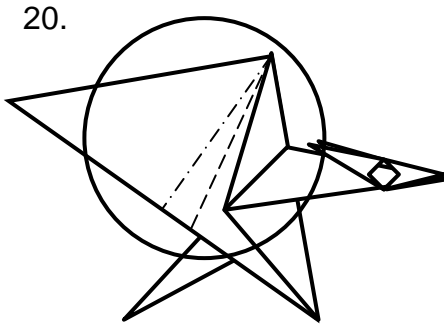

Double-crimp the wings as shown. Note that the view of the wings from the opening looks like this. The next few steps will focus on the wing.

Petal-fold the flap inside, squashing there to eliminate the flap. Repeat this step on the other side of the wing and the other wing. We will now focus on the legs.

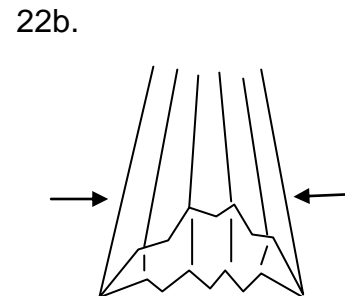
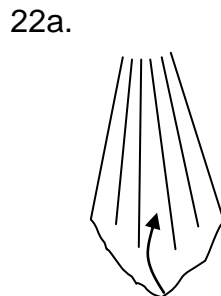
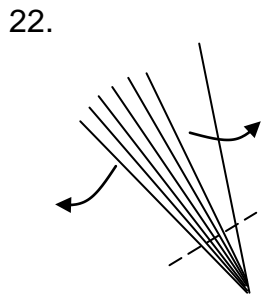

Open up the leg and fold the point in. The next few steps show this in detail.

Opened-up view. Fold the point up...

...and collapse it together again...

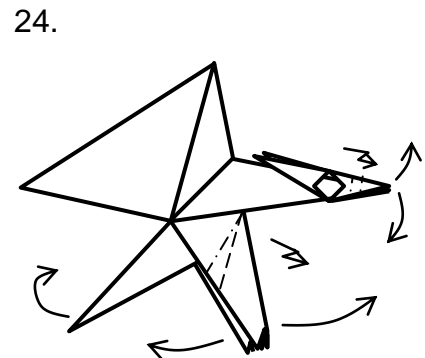
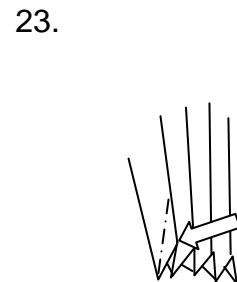
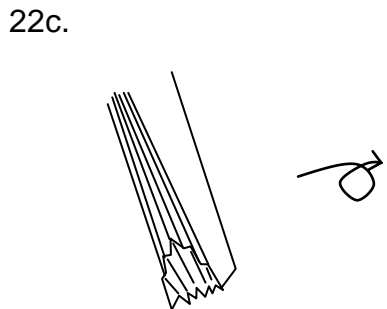

...like this. Flip the leg over to the other side.

Spread-squash the corners to form 5 toes for the leg. Repeat on all the legs.

Separate the legs with crimps, open the mouth and curve the tail. Shape to taste.